

Specifications

Hydraulic Rough Terrain Crane

HSP-8060

60-ton (54.43 metric ton)

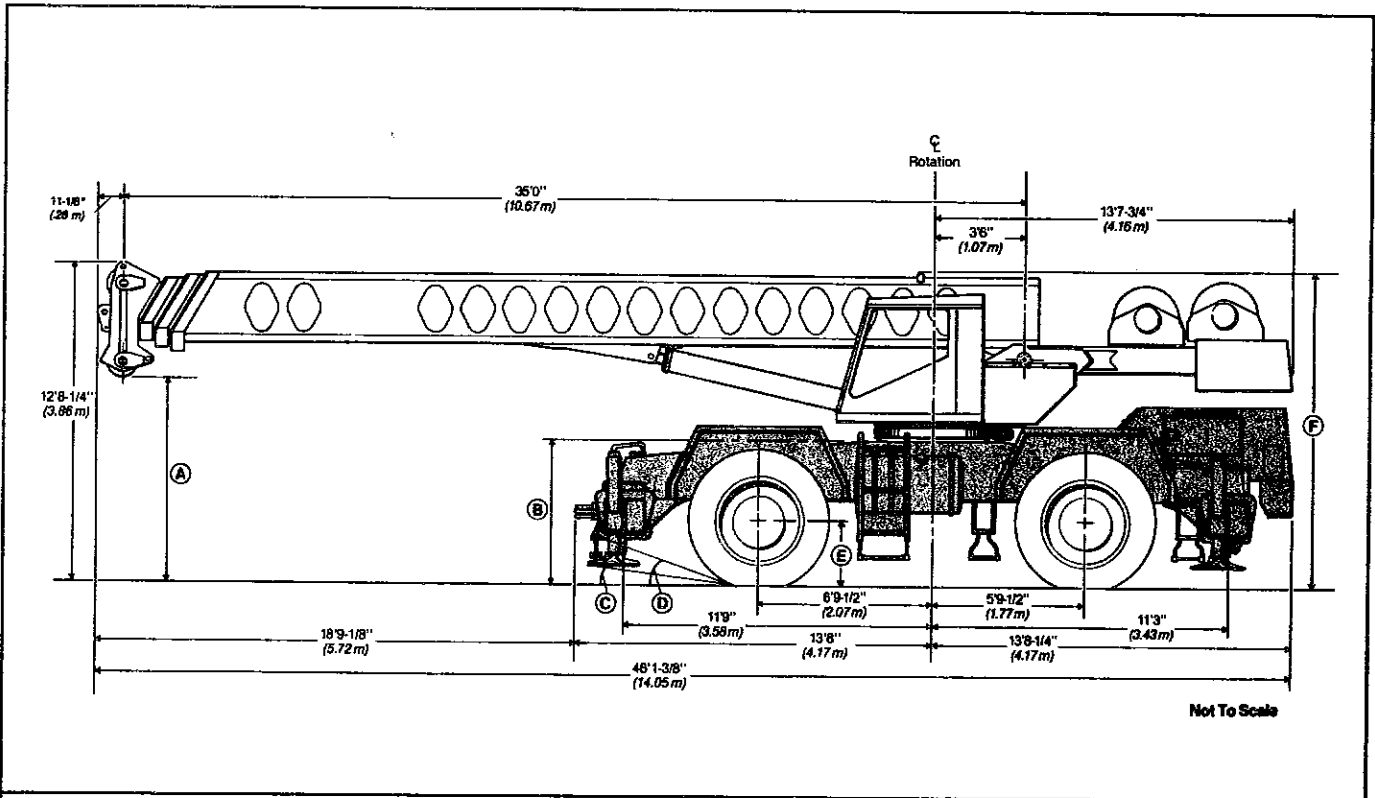

Not To Scale

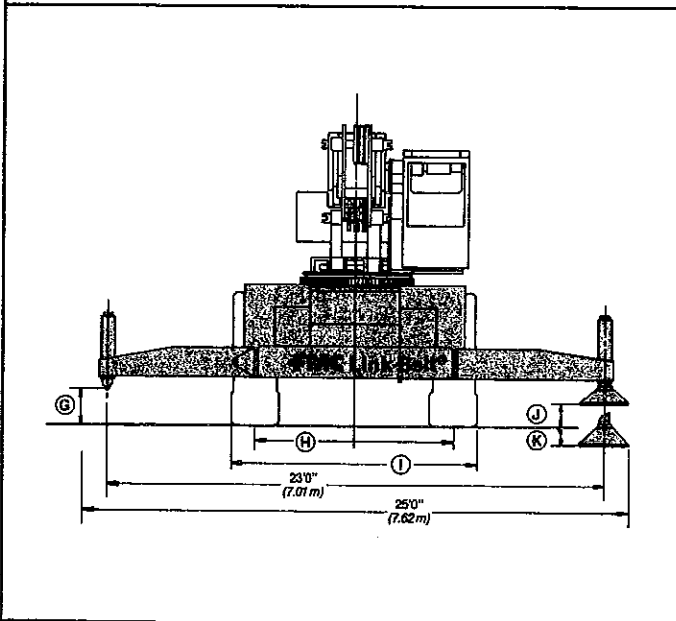

General dimensions	Feet	meters
Turning radius (4-wheel steer) \varnothing TIRE	25'	7.62
Tailswing of counterweight	14' 1/8"	4.27

Dimensions affected by tires

Tires	29.5 x 25 (22-PR)	
	Feet	meters
A	7'10-3/4"	2.41
B	5'11"	1.80
C	10.97°	—
D	24.5°	—
E	2'8"	.81
F	12'4"	3.76
G	1'9-5/16"	0.54
H	8'2-1/2"	2.50
I	10'9-1/2"	3.28
J	11-5/16"	.29
K	7-9/32"	.18

Upperstructure



Boom

FMC patented design 35'-110' (10.67-33.53 m) four section boom consisting of a base section, two power sections and a manual section. Boom side plates have diamond-shaped impressions for superior strength-to-weight ratio and 100,000 p.s.i. (689.5 MPa) steel angle chords for lateral stiffness. Boom telescope sections are supported by wear shoes both vertically and horizontally. Anti-two block with audio visual warning.

Boom head—Five 16-3/8" (0.42 m) root diameter head sheaves handle up to 10 parts of wire rope. Two easily removable wire rope guards; rope dead end lugs provided on each side of boom head.

Auxiliary lifting sheave — Optional. Single 16-3/8" (0.42m) root diameter head sheave with removable wire rope guard, mounted to boom, for use with one or two parts of line off the optional auxiliary winch. Does not affect erection of fly or jib, or use of main head sheave for multiple reeving.

Boom elevation — Two FMC designed hydraulic cylinders with holding valves. Self-aligning steel bushings. Hand and optional foot controls for controlling the 4-section boom elevation from -3° to 78°. Boom angle indicator is standard.

Fly
Optional. 33'0" (10.06m) stowable one-piece lattice type.

Jib
Optional. 25'0" (7.62m) stowable A-frame which can be offset 5°, 17.5°, and 30°. Attaches to fly only.



Cab and Controls

Environmental cab; isolated from sound and vibration by a neoprene seal. All windows are tinted and tempered safety glass. Sliding rear window and swing up roof window for maximum visibility and ventilation. Slide-by-door opens to 36" (0.91 m) width. 6-way adjustable operator seat. 4-way adjustable tilt/telescoping steering wheel. Control levers for swing, boom telescope, winch and boom hoist with foot control swing brake. Outrigger controls, sight level bubble. Optional foot control for boom hoist.

Cab instrumentation — Dash mounted gauges for hydraulic oil temperature, converter temperature, oil pressure, water temperature, fuel and voltmeter.



Swing

Bi-directional hydraulic swing motor mounted to a planetary reducer for 360° continuous smooth swing at 2.45 r.p.m.

Swing brake — Standard, manually applied, spring released, disc brake mounted on the speed reducer.

Swing lock — Standard 360° position and a two-position travel lock operated from the operator's cab.

Counterweight — Pinned to upperstructure frame.



Hydraulic system

Main pump — Tandem, triple gear-type pump. Powered by torque converter through a pump disconnect. Pump disconnect is a jaw-type clutch engaged/disengaged from carrier.

Steering/outrigger pump — Single gear-type pump. Powered by torque converter through a straight mechanical drive. Pump operates at 2,700 p.s.i. (186.25 bars).

Reservoir — FMC 140 gallon (530.0 L) capacity. Diffusers for deaeration.

Filtration — One two-micron filter located inside of the hydraulic reservoir. Accessible for easy replacement.

Control valves — Six separate control valves allow simultaneous operation of all crane functions.



Load hoist system

Standard: Model 2M17 rear winch with two-speed motor and automatic brake; power up/power down mode of operation. Bi-directional gear type hydraulic motor.

Optional: Model 2M17 front winch with two-speed motor and automatic brake, power up/power down mode of operation. Bi-directional, gear-type hydraulic motor.

Optional: Model 3M17 winch with power up/power down, two-speed motor and exclusive FMC controlled true gravity free fall. Available on rear winch only.

Line pulls and speeds—Maximum available line pull 15,870 (7 199 kg) and maximum line speed 548 f.p.m. (167.03 m/min.) on 17" (0.43 m) root diameter standard smooth or optional grooved drum.

Optional upperstructure equipment

Electronic boom angle and boom length indicator, propane heater, diesel heater, air conditioning, rear view mirrors, seat belt, warning horn, drum rotation indicators, 60-ton (54.43 metric ton) hook block, 8-1/2 ton (7.71 metric ton) hook ball and swivel, load moment device, back-up alarm, rear steer indicator, two single sealed beam headlights, front and rear directional signals, stop and tail lights, boom-mounted working light, engine monitoring system, top hatch wiper, windshield washer, foot and hand throttle, right side sliding window, counterweight removal system, lifting lugs, tachometer, amber rotating beacon, automatic swing brake, cab spotlight, hydraulic heater, grooved drums, anti-two block with function kickout.

Chassis



Type

FMC 10' 10" (3.30 m) wide, 151" (3.84 m) wheelbase.

4x4x4 - (4-wheel steer, 4-wheel drive) Standard; for rough terrain with limited turning area.

4x4x4 - (4-wheel steer, 4-wheel drive) Optional; no-spin differential on front axle; for rough terrain with limited turning area.

Frame — FMC designed, 100,000 p.s.i. (689.5 MPa) steel, double walled construction with integral 100,000 p.s.i. (689.5 MPa) steel outrigger boxes.



Axles

Front-Standard; Rockwell heavy duty planetary drive/steer type.

Rear-Standard; Rockwell heavy duty planetary drive/steer type.

Front-Optional; heavy duty no-spin high traction differential, planetary drive/steer type.

Suspension

Front axle — Rigid mounted to frame.

Rear axle — Pin-mounted on bronze bushings. Automatic hydraulic rear axle oscillation lockout cylinders engage when upperstructure rotates past 2-1/2° of centerline.

Tires

Front and rear — Standard 29.50 x 25 (22-PR) Earthmover type.



Brakes

Service — Air over hydraulic, drum-type brakes at each wheel end. Drum diameter 20 1/4" (0.51 m). Shoe width 4" (101.6 mm). Shoe area 171 sq. in. (1103.30 cm²) per wheel end.

Parking/emergency — Disc, calliper type spring applied, air released, fade resistant; cab controlled; mounted on front axle.

Steering — Hydraulic two wheel, four wheel and "crab" steering.

Transmission — Clark 3-speed, 2-range power shift transmission. Six speeds available forward and two speeds reverse. Front axle disconnect for 2 or 4-wheel drive control.



Outriggers

Four hydraulic, beam and jack outriggers. Vertical jack cylinders equipped with integral holding valve. Beams extend to 23' 0" (7.01 m) centerline-to-centerline and retract to within 10' 10" (3.30 m) overall width with floats stored. Equipped with stowable, lightweight 24" (0.61 m) diameter floats. Controls and sight level bubble located in upperstructure cab.

Miscellaneous standard equipment

Skid resistant finish on all walking surfaces, fenders, reflectors, access steps and grab handles, hydraulic oil cooler, pontoon storage, reflectors, automatic front axle disconnect, pump disconnect.

Optional chassis equipment

Towing shackles, ether injector, 24-volt start for G.M. engine, no-spin differential on front axle, spare tires and rims, pintle hook, jack cylinder hose covers, propane fired engine block heater, air dryer and emergency steering system.

Travel Speeds and Gradeability

Engine	Tires	Maximum Speed		Gradeability at stall	Maximum tractive effort at stall		Gradeability at 1.0 m.p.h. (1.61 km/h)	Maximum tractive effort at 1.0 m.p.h. (1.61 km/h)	
		m.p.h.	Km/h		pounds	kilograms		pounds	kilograms
GM 6V53N	29.5x25	21	33.79	147%	76,177	34 553	59%	47,559	21 572
Cummins* V-555-C	29.5x25	21	33.79	120%	71,022	32 215	48.1%	40,825	18 518

Engine	GM6V53N	Cummins V-555-C
Cylinders - cycle	6 - 2	8 - 4
Bore	3-7/8" (98.43 mm)	4-5/8" (117.47 mm)
Stroke	4-1/2" (114.30 mm)	4-1/8" (104.78 mm)
Displacement	318 cu. in. (5 211 cm ³)	555 cu. in. (9095 cm ³)
Compression ratio	21 : 1	17 : 1
Maximum brake h.p.	205 at 2700 r.p.m.	201 at 2700 r.p.m.
Idle speed	500 r.p.m.	625 r.p.m.
Peak torque	445 ft. lbs.	414 ft. lbs.
Electrical system	12 volt negative ground	12 volt negative ground
Fuel capacity	100 gallons (378.5L)	100 gallons (378.5 L)
Alternator	80 amp Delco	80 amp Delco
Crankcase capacity	18.4 quarts (17.41L)	24 quarts (22.71L)
Air Compressor	12 c.f.m. (0.34 m ³ /min)	13.2 c.f.m. (0.37 m ³ /min)

*Optional equipment

Axle loads

Base machine with standard 35'-110' (10.67 m-33.53 m) 4-section boom, rear winch with 2-speed hoisting and power up/down, 600' (182.88 m) 3/4" (19 mm) wire rope, FMC 4 x 4 x 4 carrier with GM 6V-53N engine, 29.5 x 25 tires, full fuel, rear counterweight, 5 sheave head machinery.	G.V.W.Ⓛ		Upper facing front				Upper facing rear			
			Front axle		Rear axle		Front axle		Rear axle	
	Lbs.	Kgs.	Lbs.	Kgs.	Lbs.	Kgs.	Lbs.	Kgs.	Lbs.	Kgs.
		86,618	39,283	43,406	19,685	43,212	19,597	36,554	16,573	50,074
33' (10.06 m) lattice fly, stowed	1,040	472	1,660	753	-620	-281	-703	-319	1,743	790
25' (7.62 m) A-frame jib, stowed	1,128	512	1,438	652	-310	-141	-402	-182	1,530	694
Hook block at bumper	1,165	575	1,883	830	-718	-355	—	—	—	—
Headache ball at bumper	325	147	525	238	-200	-91	—	—	—	—
Auxiliary lifting sheave	150	68	488	212	-318	-144	-330	-150	480	218
Fly and jib stowage brackets	230	104	343	156	-113	-51	-132	-60	362	164
Cummins engine	370	168	67	30	303	137	—	—	—	—

Ⓛ Adjust gross vehicle weight & axle loading according to component weight.

Note: All weights are ± 3%

Tire	Max. Axle Load @ 20 MPH (32.17 km/h)
29.5 x 25 - 22 PR	49,500 lbs. (22,451 Kg.)

Ⓛ Link-Belt is a registered trademark.

We are constantly improving our products and therefore reserve the right to change designs and specifications.

Link-Belt Construction Equipment Company Lexington, Kentucky



Lifting Capacities

Hydraulic Rough Terrain Crane

HSP-8060 60-ton (54.5 metric ton)

4-Section Boom

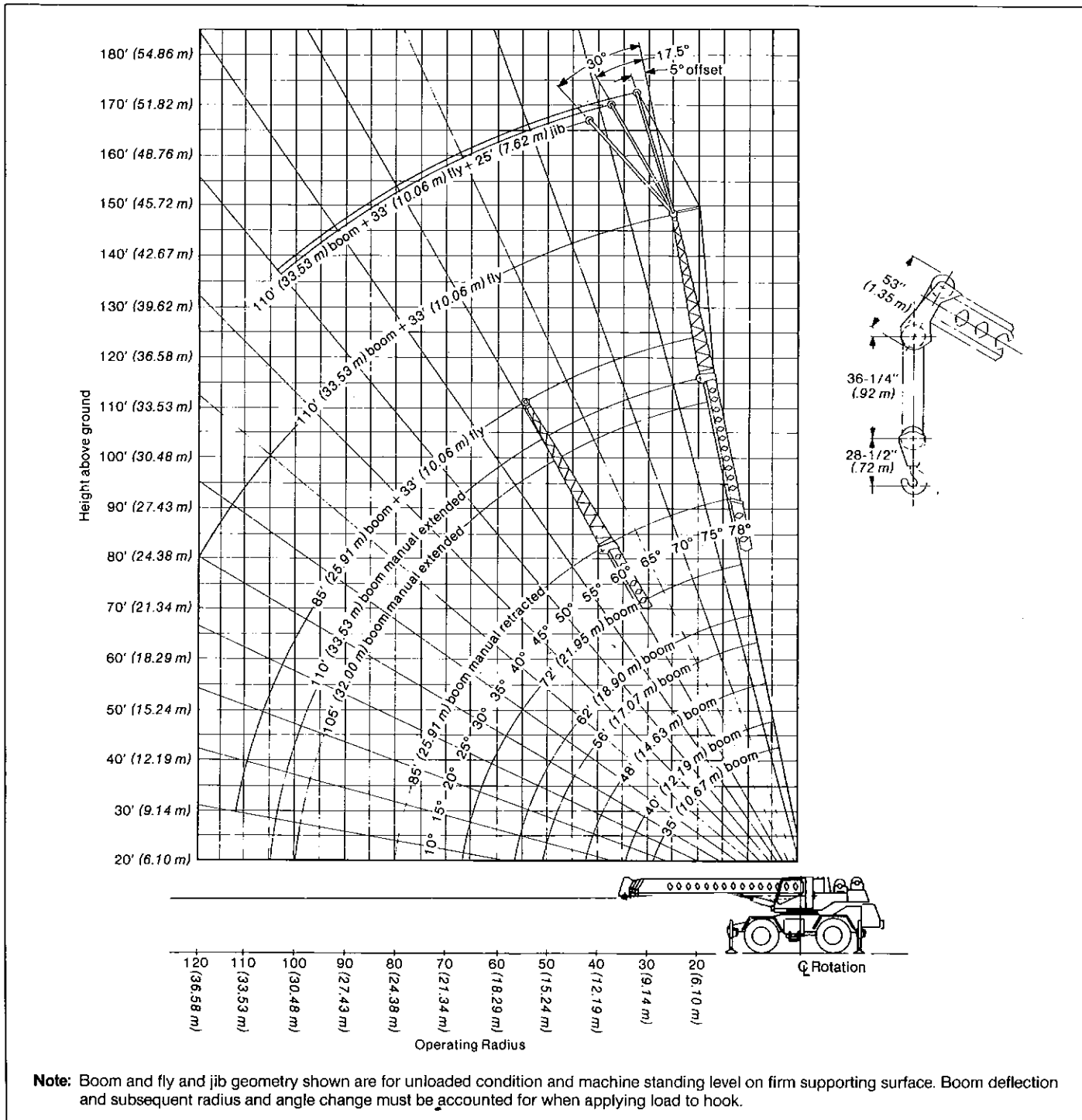

HSP-8060 Lifting Capacities

35' - 110' (10.67-33.53 m) 4-section boom

Refer to Operating Instructions page 4

Capacities On Outriggers ^① Manual Section Retracted																77' (23.47 m) boom plus 33' (10.06 m) fly			85' (25.91 m) boom plus 33' (10.06 m) fly																					
Load radius	35' (10.67 m)		40' (12.19 m)		48' (14.63 m)		56' (17.07 m)		62' (18.90 m)		72' (21.95 m)		85' (25.91 m)		Boom angle	33' (10.06 m) fly		33' (10.06 m) fly																						
	Front	360°	Front	360°	Front	360°	Front	360°	Front	360°	Front	360°	Front	360°		Front	360°	Front	360°																					
10' 3.05 m	120,000 54431	120,000 54431	90,600 41096	90,600 41096	87,100 39509	87,100 39509	86,100 39055	86,100 39055							See Note ②																									
12' 3.66 m	98,300 44589	98,300 44589	90,600 41096	90,600 41096	87,100 39509	87,100 39509	80,000 36288	80,000 36288	67,700 30709	67,700 30709										See Note ②																				
15' 4.57 m	84,000 38102	84,000 38102	82,400 37777	82,400 37777	79,500 36061	79,500 36061	69,800 31661	69,800 31661	59,400 26944	59,400 26944	51,800 23496	51,800 23496													See Note ②															
20' 6.10 m	65,000 29484	65,000 29484	65,000 29484	65,000 29484	63,400 28758	63,400 28758	57,200 25946	57,200 25946	49,000 22226	49,000 22226	43,200 19596	43,200 19596	36,600 16602	36,600 16602																See Note ②										
25' 7.62 m	50,200 22771	50,200 22771	50,200 22771	50,200 22771	50,200 22771	50,200 22771	48,100 21818	48,100 21818	41,300 18734	41,300 18734	36,800 16692	36,800 16692	30,500 13835	30,500 13835																					76°	22,200 10070	22,200 10070	77°	18,500 8392	18,500 8392
30' 9.14 m			40,400 18325	40,400 18325	40,400 18325	40,400 18325	40,400 18325	40,400 18325	35,500 16103	35,500 16103	31,800 14424	31,800 14424	25,800 11703	25,800 11703																					74°	22,200 10070	22,200 10070	75°	17,500 7938	17,500 7938
35' 10.67 m					33,300 15105	31,900 14470	33,300 15105	31,900 14470	31,100 14107	31,100 14107	27,800 12602	27,800 12602	22,300 10115	22,300 10115																					71°	20,200 10070	20,000 10070	72°	15,500 7031	15,500 7031
40' 12.19 m					26,600 12066	25,000 11340	26,600 12066	25,000 11340	26,600 12066	25,000 11340	24,500 11113	24,500 11113	19,400 8800	19,400 8800																					68°	18,900 8573	18,900 8573	70°	13,900 6305	13,900 6305
45' 13.72 m						21,500 9752	20,100 9117	21,500 9752	20,100 9117	21,500 9752	20,100 9117	17,100 7757	17,100 7757	66°																					17,300 7847	17,300 7847	67°	12,400 5625	12,400 5625	
50' 15.24 m							17,500 7938	16,400 7439	17,500 7938	16,400 7439	17,500 7938	16,400 7439	15,400 6985	15,400 6985																					63°	15,400 6985	15,400 6985	64°	10,900 4944	10,900 4944
55' 16.78 m								14,700 6688	13,700 6214	14,700 6688	13,700 6214	13,800 6260	13,700 6260	60°	14,300 6486	14,300 6486	62°	9,600 4355	9,600 4355																					
60' 18.29 m									12,400 5625	11,500 5216	12,400 5625	11,500 5216	10,400 4717	9,700 4400	57°	13,200 5988	13,200 5988	59°	8,600 3901	8,600 3901																				
65' 19.81 m										10,400 4717	9,700 4400	10,400 4717	9,700 4400	53°	12,300 5579	11,800 5352	56°	7,700 3493	7,700 3493																					
70' 21.34 m											8,900 4037	8,200 3720	8,900 4037	8,200 3720	50°	11,000 4990	10,300 4672	53°	6,900 3130	6,900 3130																				
80' 24.38 m											6,400 2903	5,800 2631	6,400 2903	5,800 2631	42°	8,500 3856	7,900 3583	46°	5,600 2540	5,600 2540																				
90' 27.43 m															33°	6,600 2994	6,100 2767	39°	4,600 2087	4,600 2087																				
100' 30.48 m															21°	5,100 2313	4,700 2132	30°	3,900 1769	3,900 1769																				
110' 33.53 m																		17°	3,400 1542	3,400 1542																				

Wire rope size and type

Wire rope application	Size and type used	Wire rope description
Main winch	3/4" (19 mm) diameter, Type "N"	Type "N" - 6 x 25 (6 x 19 class) filler wire, extra improved plow steel, preformed, independent wire rope core, right lay, regular lay.
Auxiliary winch	3/4" (19 mm) diameter, Type "N"	
Jib frontstay pendants ④	1/2" (13 mm) diameter, Type "N"	
Jib backstay pendants ⑤	1/2" (13 mm) diameter, Type "N"	

Drum wire rope capacities

Wire rope layer	Main and auxiliary drum 17" (0.43 m) root diameter smooth and grooved lagging			
	3/4" (19 mm) wire rope			
	Rope per layer		Total wire rope	
	Feet	meters	Feet	meters
1	97	29.57	97	29.57
2	111	33.83	208	63.40
3	114	34.75	322	98.15
4	122	37.19	444	135.33
5	130	39.62	574	174.96
6	139	42.37	713	217.32
7 ⑥	140	42.67	853	259.99

Footnotes

- ① All capacities on outriggers are based on outriggers fully extended with boom sections extended equal distance.
- ② Calculating capacities for extended or retracted boom plus fly must be based on boom angle only for boom lengths other than those listed. See Operating Instructions Number 14
- ③ See Operating Instructions, set-up Number 4.
- ④ Jib frontstay pendants — 24' 5-3/8" (7.45 m)
- ⑤ Jib backstay pendants — 32' 3/4" (9.77 m)
- ⑥ For storage purposes only — not a working layer.

Capacities On Tires

Load Radius	Max. boom length	Pick & Carry ^③	Stationary	
		Over Front	360°	Over Front
10' 3.05 m	35' 10.67 m	59,500 26 989	48,500 22 000	61,900 28 078
12' 3.66 m	35' 10.67 m	51,900 23 542	41,200 18 688	54,600 24 767
15' 4.57 m	35' 10.67 m	43,100 19 550	29,300 13 290	46,200 20 956
20' 6.10 m	35' 10.67 m	33,000 14 969	18,000 8 164	35,500 16 103
25' 7.62 m	35' 10.67 m	24,700 11 203	12,000 5 442	24,700 11 203
30' 9.14 m	40' 12.19 m	17,600 7 983	8,200 3 719	17,600 7 983
35' 10.67 m	40' 12.19 m	13,200 5 986	5,800 2 631	13,200 5 986
40' 12.19 m	48' 14.63 m	10,200 4 626	4,000 1 814	10,200 4 626
45' 13.72 m	56' 17.07 m	7,900 3 583	2,700 1 224	7,900 3 583
50' 15.24 m	56' 17.07 m	6,200 2 812	—	6,200 2 812
55' 16.78 m	62' 18.90 m	4,800 2 177	—	4,800 2 177
60' 18.29 m	72' 21.95 m	3,700 1 677	—	3,700 1 677
65' 19.21 m	72' 21.45 m	2,800 1 270	—	2,800 1 270

HSP-8060 Lifting Capacities

35'-110' (10.67-33.53 m) 4-section boom

Refer to Operating Instructions page 4

Capacities① On Outriggers Manual Section Extended									
Load radius	105' (32.00m)			110' (33.53m)			110' (33.53m) boom plus 33' (10.06m) fly		
	Boom angle	Front	360°	Boom angle	Front	360°	Boom angle	Front	360°
	See Note ②			See Note ②			See Note ③		
25' 7.62m	76°	20,200 9 163	20,200 9 163	77°	19,000 8 618	19,000 9 027			
30' 9.14m	73°	20,200 9 163	20,200 9 163	74°	18,500 8 392	18,500 8 392			
35' 10.67m	71°	20,200 9 163	20,200 9 163	72°	18,000 8 165	18,000 8 165	76°	9,400 4 264	9,400 4 264
40' 12.19m	68°	18,200 8 256	18,200 8 256	69°	16,200 7 348	16,200 7 348	74°	9,400 4 264	9,400 4 264
45' 13.72m	65°	16,400 7 439	16,400 7 439	66°	14,100 6 396	14,100 6 396	72°	9,000 4 082	9,000 4 082
50' 15.24m	62°	15,000 6 804	15,000 6 804	63°	12,700 5 761	12,700 5 761	70°	8,400 3 810	8,400 3 810
55' 16.76m	59°	13,800 6 260	13,800 6 260	60°	11,300 5 126	11,300 5 126	68°	8,000 3 629	8,000 3 629
60' 18.29m	55°	12,700 5 761	12,700 5 761	57°	10,300 4 672	10,300 4 672	66°	7,300 3 311	7,300 3 311
65' 19.81m	52°	11,800 5 352	11,400 5 171	54°	9,200 4 173	9,200 4 173	64°	6,500 2 948	6,500 2 948
70' 21.34m	48°	10,600 4 808	9,900 4 491	50°	8,300 3 765	8,300 3 720	61°	5,700 2 586	5,700 2 586
80' 24.38m	40°	8,000 3 629	7,500 3 402	43°	6,600 2 994	6,600 2 994	56°	4,600 2 087	4,600 2 087
90' 27.43m	29°	6,200 2 812	5,700 2 586	34°	5,800 2 631	5,600 2 540	51°	3,600 1 633	3,600 1 633
100' 30.48m	12°	4,700 2 132	4,200 1 905	22°	4,600 2 087	4,200 1 905	46°	2,800 1 270	2,800 1 270
110' 33.53m							39°	2,100 953	2,100 953
120' 36.58m							32°	1,500 680	1,500 680

- ① All capacities on outriggers are based on outriggers fully extended with boom sections extended equal distance.
- ② Calculating capacities for extended or retracted boom with manual section extended must be based on boom angle only. See Operating Instructions Number 13.
- ③ Calculating capacities for extended or retracted boom with manual section extended plus fly must be based on boom angle only. See Operating Instructions Number 15.

Jib Capacities			
33' (8.84 m) fly plus 25' (7.62 m) jib			
Boom angle	Jib Offset		
	5°	17.5°	30°
78°	5,100 2 313	5,100 2 313	4,200 1 905
75°	5,100 2 313	5,100 2 313	4,000 1 814
70°	5,100 2 313	4,900 2 223	3,600 1 633
65°	4,500 2 041	4,100 1 860	3,400 1 542
60°	3,700 1 678	3,300 1 497	2,800 1 270
55°	3,000 1 361	2,700 1 225	2,400 1 089
50°	2,500 1 134	2,300 1 043	2,000 907

HSP-8060 hydraulic circuit pressure settings		
Circuit	Function	Pressure
Main	Boom hoist	2,900 p.s.i. (200.0 Bars)
	Wire rope hoist	2,750 p.s.i. (189.66 Bars)
Secondary	Swing	1,500 p.s.i. (103.45 Bars) at port relief
	Innermid telescope Steering	2,500 p.s.i. (172.41 Bars)
	Outermid telescope	2,700 p.s.i. (186.21 Bars)
	Outriggers	2,700 p.s.i. (186.21 Bars)
Charge Pump	Winch brake and clutch	1,500 p.s.i. (103.45 Bars)

Line Speeds and Pulls

Layer	Speed	Main or auxiliary winch -17" (0.43 m) drum			
		Line Speeds		Available Line Pulls	
		F.p.m.	m/min.	Lbs.	kgs.
First	Low	172	52.43	15,870	7 199
	High	364	110.95	7,520	3 411
Second	Low	187	57.00	14,630	6 636
	High	394	120.09	6,930	3 143
Third	Low	201	61.26	13,580	6 160
	High	425	129.54	6,430	2 917
Fourth	Low	216	65.84	12,660	5 743
	High	456	138.99	6,000	2 722
Fifth	Low	230	70.10	11,860	5 380
	High	487	148.44	5,620	2 549
Sixth	Low	245	74.68	11,160	5 062
	High	517	157.58	5,280	2 395
Seventh	Low	260	79.25	10,530	4 776
	High	548	167.03	4,990	2 264

Tire Inflation

Tires	Ply	Pressure
29.5 x 25	22	60 p.s.i. (2.14 Bars)

Warning and Operating Instructions HSP-8060

General:

1. Rated lifting capacities in pounds as shown on lift chart pertain to this machine as originally manufactured and normally equipped by Link-Belt Construction Equipment Company. Modifications to the machine or use of optional equipment other than that specified can result in a reduction of capacity.
2. Construction equipment can be dangerous if improperly operated or maintained. Operation and maintenance of this machine must be in compliance with the information in the operator's parts and safety manuals supplied with this machine. If these manuals are missing, order replacements through the distributor.
3. The operator and other personnel associated with this machine shall fully acquaint themselves with the latest applicable American National Standards Institute (ANSI) Safety Standards for cranes.
4. All capacities are in pounds with metric equivalent in italic.

Set-Up:

1. Capacities included in this chart are the maximum allowable crane capacities and are based on the machine standing level on firm supporting surface under ideal job conditions. Depending on the nature of the supporting surface, it may be necessary to have structural supports under the outrigger floats or tires to spread the load to a larger bearing surface.
2. When making lifts on outriggers, outrigger beams must be fully extended with tires free of supporting surface.
3. Ten parts of 3/4" (19 mm) diameter Type "N" wire rope required to lift maximum 120,000 lbs. (54 431 kg) rated load.
4. Crane Capacities on tires depend on tire capacity, condition of tires, and tire pressure. On-tire picks require lifting from main boom head only on a smooth and level surface. Pick and carry operations (creep), are restricted to 1.0 m.p.h. (1.61 km/h) with the boom centered over front, the travel swing lock engaged and the load restrained from swinging. Lifts with the manual extended, fly or fly/jib combination erected are prohibited.
5. When making lifts on rubber, tires must be inflated to the recommended pressure and power sections must be equally extended.

Operation:

1. Rated lifting capacities at rated radius shall not be exceeded. Do not tip the machine to determine allowable loads. For clamshell and concrete bucket operation, weight of bucket and load shall not exceed 80% of rated lifting capacities. Clamshell bucket weight including bucket content is restricted to a maximum of 7,000 pounds (3175 kg) with a maximum boom length of 56 feet (17.07 m) and a minimum boom angle of 35°. Manual extended, fly or fly/jib combinations are prohibited for clam work.
2. The crane capacities shown on outriggers do not exceed 85% of the tipping loads and crane capacities shown on tires do not exceed 75% of the tipping loads as determined by SAE crane stability test code J-765a. Those capacities above the heavy bold line indicate capacities based on factors other than those which would cause a tipping condition.

3. Do not operate at boom lengths or beyond radii where no capacities are shown. Machine may overturn without any load on the hook.
4. To determine capacities in-between those shown on charts, refer to the rated lifting capacity of the next longer and next shorter booms for the same radius. The lesser of the two capacities will apply.
5. When making lifts at a load radius not shown on charts, use the next longer radius to determine allowable capacity.
6. Crane capacities are based on freely suspended loads and make no allowance for such factors as the effect of wind, sudden stopping of loads, supporting surface conditions, inflation of tires, and operating speeds. Operator must reduce load ratings to take such conditions into account. Deductions from rated capacities must be made for weight of hook block, weighted ball/hook, sling, spreader bar, fly or other suspended gear.
7. Rated lifting capacities are based on correct reeving. Deduction must be made for excessive reeving. Any reeving over minimum required is considered excessive and must be taken into account. Use working range plate to estimate the extra feet of rope and then deduct 1 lb. (4536 kg) for each foot of wire rope before attempting to lift a load.
8. The following deductions from rated main boom capacities must be made if the machine is equipped with the following:
 - a. auxiliary lifting sheave - 200 lbs. (91 kg.)
 - b. 33' (10.06 m) one-piece fly stowed on boom - 700 lbs. (318 kg).
 - c. 33' (10.06 m) one-piece fly in working position - 1,800 lbs. (816 kg)
 - d. 33' (10.06 m) fly plus 25' (7.62 m) jib stowed on boom - 1,100 lbs. (499 kg)
 - e. 33' (10.06 m) fly plus 25' (7.62 m) jib in working position - 4,400 lbs. (1 996 kg)
 - f. 25' (7.62 m) jib in working position and picking from fly tip - 1,900 lbs. (862 kg)
9. Powered boom length is from 35' (10.67 m) to 85' (25.91 m).
10. Extension or retraction of the boom with loads within the limits of the applicable rating chart may be attempted. The ability to telescope loads is limited by hydraulic pressure, boom angle, boom length, boom lubrication, etc.
11. Do not move load to radii or boom lengths greater than those specified on applicable chart.
12. Effective length of boom with auxiliary lifting sheave is length shown on boom length indicator plus 2' (0.61 m).
13. The rated loads for the manual extended are determined by boom angle only for boom lengths other than 105' (32.00 m) and 110' (33.53 m) as follows: For boom lengths less than 105' (32.00 m), the rated loads are determined by boom angle only in the column headed 105' (32.00 m). For boom lengths between 105' (32.00 m) and 110' (33.53 m), the rated loads are determined by boom angle only in the column headed 110' (33.53 m) manual extended. For angles not shown, use next lower boom angle to determine allowable capacity.

14. The rated loads for the manual retracted with 33' (10.06 m) fly are determined by boom angle only for boom lengths other than 110' (33.53 m) and 118' (35.97 m) as follows: For boom lengths with fly and manual retracted less than 110' (33.53 m), the rated loads are determined by boom angle only in the column headed 110' (33.53 m) manual retracted with fly. For boom lengths with fly and manual retracted between 110' (33.53 m) and 118' (35.97 m), the rated loads are determined by boom angle only in the column headed 118' (35.97 m). For angles not shown, use the next lower boom angle to determine allowable capacity.
15. For boom lengths with fly less than 143' (44 m) with manual extended, the rated loads are determined by boom angle only in the column headed 143' (44 m). For angles not shown, use the next lower boom angle to determine allowable capacity.
16. The 25' (8 m) jib capacities are based on main boom angle, regardless of main boom length. For angles not shown, use next lower boom angle to determine allowable capacity. Capacity values are for 360 degree operation. Warning: Do not lower 25' (8 m) jib in working position below 50 degrees unless boom is fully retracted.
17. The 35' (10.67 m) boom length capacities are based on boom fully retracted. If not fully retracted, do not exceed ratings for the 40' (12.19 m) boom length.

Definitions:

1. Load Radius: Horizontal distance from a projection of the axis of rotation to the supporting surface before loading to the center of the vertical hoist line or tackle with load applied.
2. Loaded Boom Angle: The angle between the boom base section and the horizontal after lifting the load at the rated radius. The boom angle, before loading, should be greater to account for deflections.
3. Working Area: Area measured in a circular arc about the center line of rotation as shown on the working area diagram.
4. Freely Suspended Load: Load hanging free with no direct external force applied except by the hoist line.
5. Side Load: Horizontal side force applied to the lifted load either on the ground or in the air.

HSP-8060 Working Areas

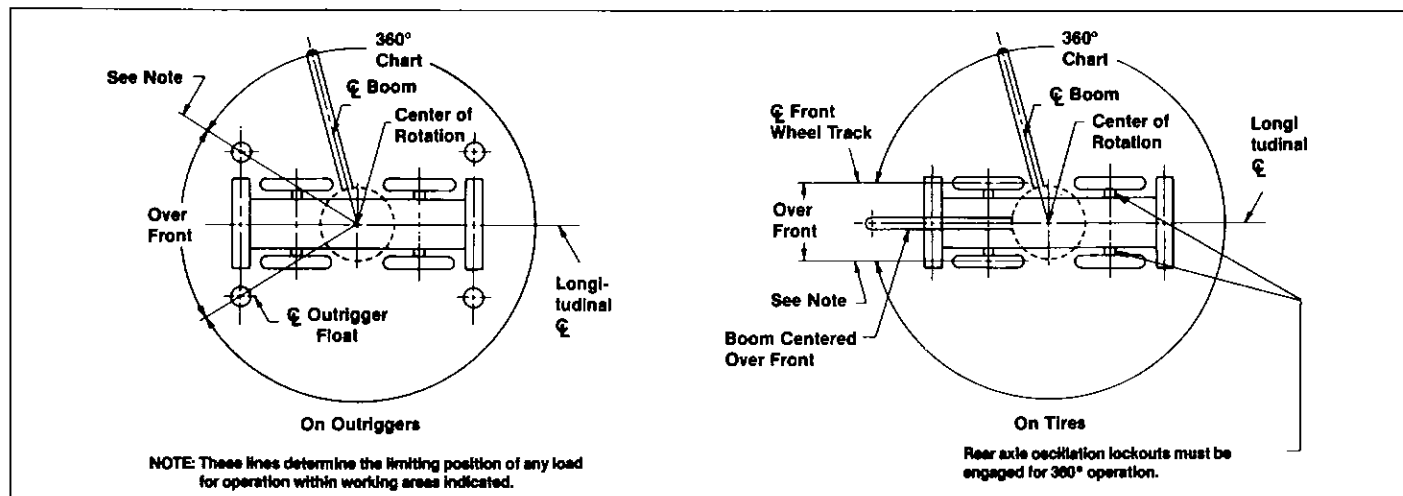

We are constantly improving our products and therefore reserve the right to change designs and specifications.
©Link-Belt is a registered trademark.

Link-Belt Construction Equipment Company Lexington, Kentucky

